

Validity of the Persian translation of the COVID-19 Attitudes and Behaviors (ACAB)

DOI: [10.22098/JPC.2023.13684.1189](https://doi.org/10.22098/JPC.2023.13684.1189)

Effat Ghavibazou¹; Simin Hosseinian^{2*}; Abbas Abdollahi¹

¹ Department of Counseling, Faculty of Education and Psychology, Alzahra University, Tehran, Iran

² Department of Counseling, Faculty of Education and Psychology, Alzahra University, Tehran, Iran.

Corresponding Author: hosseinian@alzahra.ac.ir

Abstract

Introduction: The coronavirus disease of 2019 (COVID-19) outbreak is of particular global concern. All Persian versions of COVID-19 measures assess its intrapsychic aspects, and there is a crucial need to measure the intergroup aspects of this pandemic. **Aim:** The current study aims to translate the COVID-19 Attitudes and behaviors (ACAB) into Persian and then validate the Persian version of COVID-19 attitudes and behaviors in the Iranian sample. **Method:** The participants included 250 people selected for accessibility (177 men and 73 women). **Results:** The ACAB scale had satisfactory reliability and validity according to content, face, and construct validity tests except for the first subscale (social distancing adjustment).

Consequently, confirmatory factor analysis protects the ACAB with 12-item and three subscales. Therefore, three subscales remained, including self-prioritization, prosocial behaviors, and belief in conspiracies, and social distancing adjustment was eliminated. **Conclusion:** Results indicated that the ACAB is a reliable and helpful tool in research, especially for governmental surveys, to understand why people do not cooperate in vaccination or prosocial behaviors.

Keywords: attitudes and behaviors, belief in conspiracies, COVID-19, prosocial behaviors, self-prioritization, validity.

Introduction

The World Health Organization (WHO) declared the COVID-19 pandemic a public health emergency of international concern (PHEIC) on January 30, 2020, and a pandemic on March 11, 2020, following the initial detection of the disease in Wuhan, China, in December 2019. COVID-19 is easily transmitted by contact because some social restrictions are implemented, and most events, such as cultural, sporting, religious, and political, are canceled (Döring, 2020). The most common symptoms of COVID-19 were a cough, malaise, fatigue, and shortness of breath (Abdelhafiz et al., 2020). COVID-19 was a threat to public health and is considered a crisis that caused many other problems and psychological disorders, including sexuality problems and intimacy (Banerjee & Rao, 2020; De Rose et al., 2021; Lopes et al., 2020; Panzeri et al., 2020), fear, anxiety, phobia, and depression (Brenner & Bhugra, 2020; Karagöz et al., 2020; Korukcu et al., 2021; Magano et al., 2021; Sakib et al., 2020; Q. Xie et al., 2020).

On the other hand, Coronavirus has influenced the educational, political, and economic aspects of life universally (Ardestani et al., 2021; Brenner & Bhugra, 2020; Döring, 2020; Q. Xie et al., 2020). The COVID-19 pandemic outbreak's incidents demonstrated fluctuating trends worldwide, both within and between waves, between declining and rising. There has been an increase in the number of weekly cases for the fifth consecutive week from the beginning of June 2022 to July 13, 2022, with over 5.7 million weekly new cases and over 9800 deaths reported, despite recent reports indicating that the pandemic has been trending downward since its previous peak in March 2022. Between August 1 and August 7, 2022, more than 6.9 million new weekly cases were confirmed. However, when compared to the rate of cases reported the week before, the rate of new weekly cases appeared to decrease, as it was estimated to be 24% between August 8 and August 14, 2022, with over 5.4 million new cases. The World Health Organization (WHO) reported that there had been 600,366,479 confirmed cases as of September 5, 2022. This includes a global total of 6,460,493 fatalities. As a result, it is evident from the statistics that, despite vaccinations and other precautions being taken worldwide, the course of events appears to be uncertain (Aljaberi Lee et al., 2022). Thus, there is an essential need for psychometrics to assess the attitudes and behaviors of people about COVID-19 and implement corrective solutions.

Attitudes and behaviors related to COVID-19 mean evaluating the processes in social and intergroup contexts. This evaluation has been conducted in four subscales: social distancing adjustment, self-prioritization, prosocial behaviors, and belief in conspiracies (Silverstein et al., 2021). The first subscale, social distancing adjustment, measures the difficulty of considering social distance with others. This distance is defined as at least 1.5 meters, and considering this distance, especially in public spaces, has a meaningful influence in preventing the spread of COVID-19 (Bedford et al., 2020; Memish et al., 2020). The second one, self-prioritization, measures people's tendency to initially worry about their health and well-being. The third subscale, prosocial behaviors, measures people's willingness to do things in favor of social behaviors (Silverstein et al., 2021).

Following Hirschberger's (2013) statement, people's reactions to concerns differ. If the prosocial behaviors lighten their concerns, they may boost them.

In contrast, if the prosocial behaviors embitter their fear, they may lessen them and increase behaviors that protect them against diseases and concerns (self-prioritization). Finally, belief in conspiracies measures the most common conspiracy theories about the sources and transference of COVID-19 (Silverstein et al., 2021). People's reactions to COVID-19 relate to their beliefs. According to conspiracy theories, these reactions can vary from denying COVID-19 to professing that some organizations or governments release it (Ahmed et al., 2020).

Assessment of COVID-19 Attitudes and Behaviors (ACAB) developed by Silverstein et al. (2021) in New Orleans, Louisiana, is a 16-item scale. It has four subscales, including social distancing adjustment, which comprises three items (1, 2, and 3); self-prioritization, which consists of four items (4, 5, 6, and 7); prosocial behaviors that consist of four items (8, 9, 10, and 11), and belief in conspiracies that comprised five items (12, 13, 14, 15, and 16). The original paper indicates that ACAB Cronbach's alpha values are good except for social distancing adjustment ($\alpha = 0.36$), which is less than ideal. Because of the limitation of items on each subscale, alpha values could potentially be low (Silverstein et al., 2021). The nature of COVID-19 is different from noncontagious diseases such as diabetes. The noncontagious disease is soluble with drug intervention. The contagious nature of COVID-19 requires compliance with social distancing in addition to drug use. Due to that, for a better understanding of COVID-19-related processes, one needs to understand its relationship with social and intergroup processes (Silverstein et al., 2021). The primary purpose of the questionnaire is to measure interpersonal and intergroup processes. For this reason, four subscales of social distancing adjustment, self-prioritization, prosocial behaviors, and belief in conspiracies are included (Silverstein et al., 2021).

There is no other version of this questionnaire. However, by the time COVID-19 emerged, several questionnaires were developed to assess the phobia of COVID-19 (Arpaci et al., 2020), fear of COVID-19 (Basit et al., 2021; Bitan et al., 2020; Sakib et al., 2020), the anxiety of COVID-19 (Chandu et al., 2020; Lee et al., 2020; Nikčević & Spada, 2020; Petzold et al., 2020; Silva et al., 2020), the effect of the COVID-19 pandemic on community mental health (Korukcu et al., 2021), on psychological outcomes (Aljaberi, Alareqe, et al., 2022), and smoking behavior and quit intention (Al-Tammemi et al., 2021).

As seen, most of the questionnaires are about the fear, phobia, and anxiety of COVID-19, and less attention is paid to attitudes and behaviors of COVID-19. Indeed, most questionnaires consider the intrapsychic process of COVID-19, but ACAB focused on interpersonal and external factors that can help understand the psychological processes of COVID-19. Recognizing and explaining the psychological processes of COVID-19 is essential and can support macro policy decisions and facilities. On the other hand, evaluating the attitudes and behaviors about COVID-19 is essential because it predicts

people's behavior regarding cooperation in vaccine injection and social preventive behaviors. Therefore, the authors decided to implement the validity of ACAB in Iran.

Methods

Participants and Procedures

The Ethics Committee of the Department of Counseling at ... reached an ethical agreement for the study. At first, participants included 301 people who selected availability. Then, 51 people were eliminated because they were outliers using the Z score, and 250 remained. Plichta, Kelvin, and Munro (2013) suggested a 5:1 to 20:1 ratio of cases to items for the CFA sample size. This study met the 15:1 ratio for the remaining people (250) and the items (16). Among the remaining participants, 177 were women, and 73 were men. They ranged in age from 18 to 53, with a mean age of 32.15 (SD = 9.25). The demographic characteristics of participants are shown in Table 1 (see Table 1).

Table 1. Demographic characteristics of participants.

Variable	Percent (n)
Gender	
Men	70.8 (n = 177)
Women	29.2 (n = 73)
Marital status	
single	45.6 (n = 114)
Married	50.4 (n = 126)
Divorced	4 (n = 10)
Educational level	
Under diploma	5.6 (n = 14)
Diploma	14.8 (n = 37)
Bachelor degree	43.2 (n = 108)
Master`s or doctoral degree	36.4 (n = 91)
Job	
Clerk	21.2 (n = 53)
businessman	9.6 (n = 24)
Quasi-public	8 (n = 20)

Validity of the Persian translation of the COVID-19 Attitudes and Behaviors (ACAB)

Self-employment	24.5 (n = 61)
unemployment	36.7 (n = 92)

People voluntarily participated in the study by filling out questionnaires made available through Google Forms, which were then disseminated online. Volunteering of the participation shows their consent to participate in the test. It said that no one would know anything about it. The entire process of filling out the form takes about ten minutes. Over two weeks, each questionnaire was answered.

Instruments

Assessment of COVID-19 attitudes and behaviors (ACAB) (Silverstein et al., 2021) is a 16-item scale of COVID-19 attitudes and behaviors, including four subscales: social distancing adjustment that has three items (1, 2, and 3), self-prioritization that has four items (4, 5, 6, and 7), prosaically behaviors that have four items (8, 9, 10, and 11) and belief in conspiracies that has five items (12, 13, 14, 15, and 16). Each item uses a five-point Likert scale, ranging from 0 (strongly disagree) to 4 (strongly agree). The sum of the item scores is used to calculate the overall score for each subscale. A higher score indicates more positive attitudes and actions.

The ACAB scale in its English version was translated into Persian using the Brislin (1986) method. Two specialists separately translated the ACAB scale. One expert translated the scale into Persian, and another expert translated it back into Persian. At some point, three distinct translators compared the two versions of the ACAB scale argued about their differences and came to an agreement on the Persian translation.

Connor-Davidson Resilience Scale (CD-RISC) (Connor & Davidson, 2003) is a 25-item measure that assesses resilience and the ability to deal with stress and hardship. Each item uses a five-point Likert scale from 1 (not true at all) to 5 (true nearly all the time). The total score of the CD-RISC is determined by summing up the items' scores. A higher score shows a greater level of resilience. The previous study recommends that the CD-RISC has acceptable reliability for the Iranian sample ($\alpha = 0.91$) (Mohammadi et al., 2006).

Data Analysis

In the present research, two software were used for data analysis. Firstly, descriptive statistics were used to comprehend the current sample's demographic characteristics and the tested constructs' scores, including Assessment of COVID-19 attitudes and behaviors (ACAB) and Connor-Davidson Resilience Scale (CD-RISC). The mean, standard deviation, correlation, Cronbach's Alpha Coefficient, and Z score were all carried out with the assistance of SPSS 24. All items were distributed normally. Additionally, confirmatory factor analysis, including construct validity, construct reliability, and discriminant validity, was evaluated using AMOS software (version 24). Face validity was counted using the impact score, and content validity was counted using the Content Validity Ratio (CVR) and the Content Validity Index (CVI). Structural Equation Model

(SEM) and Confirmatory factor analysis (CFA) were utilized with their model-data fit was evaluated utilizing some approximate fit indices, including the Incremental Fit Index (IFI), Comparative Fit Index (CFI), the Root Mean Squared Error of Approximation (RMSEA), and Tucker Lewis Index (TLI) with a confidence interval of lower and upper limits.

Results

Face Validity

In this study, the face validity of the ACAB scale was determined using qualitative and quantitative approaches. Ten individuals who were not the primary study participants were asked to evaluate each item's clarity, appropriateness, and ease of use in the qualitative portion. After essential corrections from the people's perspective are made, quantitative face validity is determined. As a result, ten individuals, the same as in the previous sample, were asked to rank each item on a five-point Likert scale from 1 (not important) to 5 (completely important) regarding clarity, appropriateness, and ease of use. The formula is then used to count each item's impact score: impact score equals importance divided by frequency (in percent). The mean score of an item is related to the number of participants who gave it a score of four or five, as shown by their frequency and importance. Hajizadeh and Asghari (2011) state that the items gained equal to or greater than 1.5 are considered acceptable and remain in the survey. The lower impact score threshold is 1.5. All items were maintained on the ACAB scale because the quantitative face validity test revealed that their impact factor was greater than 1.5 in this study.

Content Validity

The validity of the qualitative content was evaluated by eight experts, seven counselors, and one psychologist. They offered their comments regarding appropriate phrases, word usage, and grammar. Quantitative content validity was also evaluated. According to Cook and Beckman (2006), the Content Validity Ratio (CVR) and the Content Validity Index (CVI) were utilized as a result. As a result, a three-point Likert scale was used to ask eight experts to rate the importance of each item. Not required, 2: useful but not required, and three: necessary). To determine an item's CVR, use the formula below:

N is the number of experts, and n_e is the number of experts who gave the item a score of three in the formula above. The findings indicate that the CVR for every item was greater than the Lawshe table value of 0.75. Then, all of the scale's items had acceptable content validity (Lawshe, 2006). On a four-point Likert scale: (1) not at all appropriate, (2) somewhat appropriate, (3) quite appropriate, and (4) highly appropriate, CVI was used to evaluate the items' ease of use, clarity, and appropriateness. According to the findings, all of the items' CVI values were greater than 0.70. It shows that all of the items had acceptable content validity.

Construct Validity

Data preparation

No data is missing because of the use of a Google Form and the determination of all items that must be answered. The standard score (Z) was used to evaluate the outliers, and the SPSS (Statistical Package for the Social Sciences) software analysis revealed that some of the data had a value greater than 2.58 (Tabachnick et al., 2007). All data that did not meet these criteria were eliminated. Before applying the confirmatory factor analysis, the normality analysis was evaluated. The skewness values found in the analysis of the moment structure section of the AMOS software (version 24) ranged from -2.70 to 2.43. The data were distributed normally, as evidenced by the kurtosis values ranging from -0.39 to 6.75 (the acceptable range for skewness and kurtosis is ± 3 , ± 7) (X.-Q. et al., 2019).

Confirmatory Factor Analysis

The AMOS software was used to conduct confirmatory factor analysis (CFA) with maximum likelihood estimation to examine the structural validity of the four factors of the ACAB scale. There are three items in factor one, four in factors two, three, and five in factor four. For confirming confirmatory factor analysis, a sample size between 5 and 20 times larger than the total number of items on the questionnaire is acceptable (Plichta et al., 2013). As a result, 250 people took part in this study. First, the items' factor loadings are monitored. Kline (2015) states that factor loadings of more than 1, negative, or less than 0.4 of each item must be removed.

The CFA results illustrated that all factor loadings were less than 1, more than 0.4, and not negative except items 1, 2, 3, and 4; their factor loadings were respectively 0.21, 0.11, 0.21, and 0.31 (all items had significant relationships with the latent variables at the level of 0.001). Accordingly, items 1, 2, 3, and 4 were eliminated. Therefore, one of the factors (social distancing adjustment) was eliminated.

The CFA results endorsed that the ACAB scale effectively manifests three factors of assessment of COVID-19 attitudes and behaviors (self-prioritization, prosocial behaviors, and belief in conspiracies). All of the items had significant relationships with the latent variables ($P < 0.001$), as shown in the correlation analysis results (Figure 1). Self-prioritization and prosocial behavior had the highest correlation coefficient ($r = -0.39$), while belief in conspiracies and prosocial behavior had the lowest ($r = -0.12$). Table 2 shows the mean and standard deviation for each ACAB scale item (see Table 2).

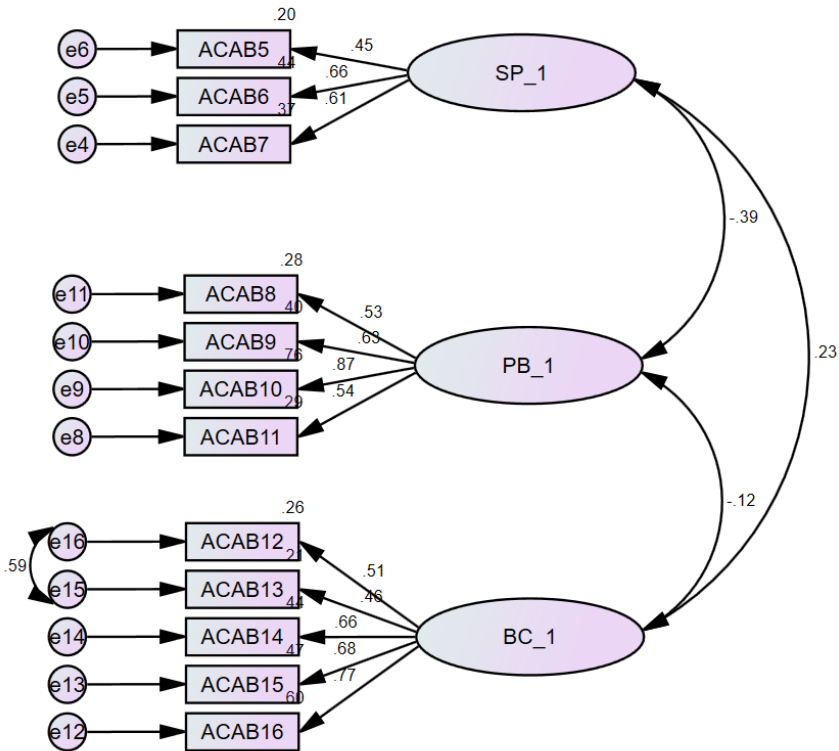

Figure 1. Confirmatory factor analysis with the three subscales of the ACAB scale ($p < 0.001$). Note: Self-prioritization (ACAB5, ACAB6, and ACAB7), Prosocial behaviors (ACAB8, ACAB9, ACAB10, and ACAB11), and Belief in conspiracies (ACAB12, ACAB13, ACAB14, ACAB15, and ACAB16).

Second, the fit indices were measured using the following fit thresholds: RMSEA (root mean square error of approximation) less than or equal to 0.08; the Incremental-Fit Index (IFI) was higher than 0.90; Statistics of chi-square fit/degree of freedom (CMIN/df) less than 5; the Tucker-Lewis Index (TLI) was higher than 0.90; and Comparative-Fit Index (CFI) was more significant than 0.90 (Byrne, 2013). The results of this measurement showed that the remaining ACAB scale items and subscales (RMSEA = 0.03, IFI = 0.97, CMIN/df = 1.38, TLI = 0.96, and CFI = 0.97) fit the data well.

Table 2. Mean and standard deviation of items of COVID-19 attitudes and behaviors.

No	Items	Mean	Std. Deviation
----	-------	------	----------------

Validity of the Persian translation of the COVID-19 Attitudes and Behaviors (ACAB)

5	Purchasing thousands of dollars` worth of hand sanitizer, gloves, Clorox, and masks and reselling them at higher prices is good business practice.	.63	1.09
6	There is nothing wrong with “stockpiling” or buying large quantities of goods if one can afford to.	.73	1.09
7	If I can afford to buy it, I should be able to buy whenever I deem necessary during the COVID-19 pandemic even if it means there will be shortage of supplies for others.	.50	1.04
8	If my immunocompromised roommate or friend asked me to go to the grocery store for them, I would do it even if I didn`t need to buy anything.	3.48	1.00
9	I would take special precautions to accommodate the health concerns of a stranger, even if they were inconvenient for me.	2.98	1.06
10	I would take special precautions to accommodate the health concerns of a friend, even if they were inconvenient for me.	3.39	.84
11	I would take special precautions to accommodate the health concerns of a family member, even if they were inconvenient for me.	3.74	.69
12	COVID-19 was created in a laboratory and released by a government official.	2.55	1.18
13	COVID-19 is a sign from a higher power.	2.52	1.16
14	COVID-19 was purposely spread by a religious cult.	1.71	1.04
15	COVID-19 was created by the CDC.	1.69	1.02
16	COVID-19 is a government population control method.	2.10	1.17

Reliability

Overall, Cronbach's Alpha Coefficient, Convergent Validity (CV), and Construct Reliability (CR) were all evaluated. The AVE method was applied to assess the CV of the ACAB scale (an AVE > 0.5 illustrates an acceptable CV). According to the findings, AVE for ACAB did not meet the requirements (AVE = 0.39). On the other hand, according to Tabachnick et al. (2007), it had a high CR (CR = 0.78), which indicates that the scale's internal consistency reliability is high. Cronbach's Alpha Coefficient also

evaluated the ACAB scale's internal consistency. It was for three subscales of ACAB (self-prioritization, prosocial behaviors, and belief in conspiracies), respectively 0.78, 0.58, and 0.70 (Tabachnick et al., 2007).

Discriminant Validity

Connor-Davidson Resilience Scale (CD-RISC) was used to assess discriminant validity. In discriminant validity, the correlation between two questionnaires (ACAB and CD-RISC) is calculated, and this correlation should be negative. Results show that the ACAB scale had no significant correlation with CD-RISC, unlike the original paper (see Table 3).

Table 3. Correlations between the study variables.

Variables	1	2	3	4
(1) Self-prioritization	1			
(2) Prosocial behaviors	-.292	1		
(3) Belief in conspiracies	.124	-.041	1	
(4) Resilience	-.092	.175	-.018	1

Discussion

This study aims to verify the ACAB scale using data from an Iranian sample. The questionnaire was therefore translated into Persian. Therefore, there is no issue with the translated ACAB scale. Then, both the content's qualitative and quantitative validity were looked at. The results were acceptable and proper for the Iranian sample. The ACAB scale (Silverstein et al., 2021) has four factors: social distancing adjustment, self-prioritization, prosocial behaviors, and belief in conspiracies. Confirmatory factor analysis indicated that the Persian version of the ACAB scale with four factors fit into three factors (self-prioritization, prosocial behaviors, and belief in conspiracies). The factor loading values of items for the three mentioned factors were more than 0.4 (within the range of 0.45 to 0.87). Therefore, they maintained the ACAB scale. Nevertheless, the factor loading values of items 1 and 2 (social distancing adjustment) and item 4 (self-prioritization) were less than 0.4 (within the range of 0.07 to 0.24), and item 3 (social distancing adjustment) was more than 1 (2.03); hence, they eliminated.

The ACAB scale's remaining three factors were found to have good internal consistency, as demonstrated by the CR coefficients and Cronbach's alpha. The Cronbach's alpha for the social distancing adjustment factor in the original paper (Silverstein et al., 2021) was low (0.39), which shows this factor is unsatisfactory internal consistency. It is consistent with the translated version's results and eliminates this factor. The results show those of (Silverstein et al., 2021), who also found that the four-factor ACAB scale had no statistically significant correlation with CD-RISC (within the range of -0.29 to 0.17).

The findings may help us to understand why some people have no self-prioritization behaviors (like using masks, gloves, and alcohol), prosocial behaviors (like helping others and considering their health concerns), and belief in conspiracies (who deny COVID-19 or attribute it to the governmental institutions). Conspiratorial beliefs are so important because they determine people's behaviors in other aspects. For example, how strong

these beliefs are, they will not consider their health and the health of others. Also, they determine their tendency to vaccinations (Allington & Dhavan, 2020; Bednarczyk, 2018).

Limitations and future directions

A limitation of this study is that evaluating only discriminant validity. More broadly, research is also needed to determine the convergent validity of the four-factor ACAB scale with the Delaying Gratification Inventory (DGI). In addition to CR coefficients and Cronbach's alpha, the test-retest reliability of the ACAB scale can be evaluated. Self-report measurement can make it vulnerable to social desirability bias. Consequently, the ACAB is a reliable and helpful tool in researching, especially for governmental surveys, to understand why people do not cooperate in vaccination or prosocial behaviors.

Conclusion

This study identified ACAB as an acceptable scale among the Iranian sample. The confirmatory factor analysis results showed that three factors remained: self-prioritization, prosocial behaviors, and belief in conspiracies. However, the Iranian version of ACAB is a 12-item questionnaire. This questionnaire is important because it can predict the tendency to vaccinate, self-care, and prosocial behaviors.

References

- Abdelhafiz, A. S., Mohammed, Z., Ibrahim, M. E., Ziady, H. H., Alorabi, M., Ayyad, M., & Sultan, E. A. (2020). Knowledge, perceptions, and attitude of Egyptians towards the novel coronavirus disease (COVID-19). *Journal of Community Health, 45*(5), 881–890. <http://doi.org/10.1007/s10900-020-00827-7>
- Ahmed, W., Vidal-Alaball, J., Downing, J., & Seguí, F. L. (2020). COVID-19 and the 5G conspiracy theory: Social network analysis of Twitter data. *Journal of medical Internet research, 22*(5), e19458. <http://doi.org/10.1109/ICAC3N53548.2021.9725406>
- Al-Tammemi, A. a. B., Barakat, M., Al Tamimi, D. a., Alhallaq, S. A., Al Hasan, D. M., Khasawneh, G. M., . . . Al-Maqableh, H. O. (2021). Beliefs toward smoking and COVID-19, and the pandemic impact on smoking behavior and quit intention: findings from a community-based cross-sectional study in Jordan. *Tobacco use insights, 14*, 1179173X211053022. <http://doi.org/10.22541/au.162271681.14380296/v2>
- Aljaberi, M. A., Alareqe, N. A., Alsalahi, A., Qasem, M. A., Noman, S., Uzir, M. U. H., . . . Abdallah, A. M. (2022). A cross-sectional study on the impact of the COVID-19 pandemic on psychological outcomes: Multiple indicators and multiple causes modeling. *PloS one, 17*(11), e0277368. <http://doi.org/10.1371/journal.pone.0277368>
- Aljaberi, M. A., Lee, K.-H., Alareqe, N. A., Qasem, M. A., Alsalahi, A., Abdallah, A. M., . . . Lin, C.-Y. (2022). *Rasch modeling and multilevel confirmatory factor analysis for the usability of the impact of event Scale-Revised (IES-R) during the COVID-19 pandemic*. Paper presented at the Healthcare. <http://doi.org/10.3390/healthcare10101858>

- Allington, D., & Dhavan, N. (2020). The relationship between conspiracy beliefs and compliance with public health guidance about COVID-19.
- Ardestani, S. M. S., Khosravani, V., Bastan, F. S., & Baloğlu, M. (2021). The Persian version of the COVID-19 Phobia Scale (Persian-C19P-S) and the differences in COVID-19-related phobic reactions in patients with anxiety disorders. *International Journal of Mental Health and Addiction*, 1-17. <http://doi.org/10.1007/s11469-021-00523-0>
- Arpaci, I., Karataş, K., & Baloğlu, M. (2020). The development and initial tests for the psychometric properties of the COVID-19 Phobia Scale (C19P-S). *Personality and Individual Differences*, 164, 110108. <http://doi.org/10.1016/j.paid.2020.110108>
- Banerjee, D., & Rao, T. S. (2020). Sexuality, sexual well-being, and intimacy during COVID-19 pandemic: An advocacy perspective. *Indian Journal of Psychiatry*, 62(4), 418. http://doi.org/10.4103/psychiatry.IndianJPsychiatry_484_20
- Basit, K. A., Zafar, A. B., Fawwad, A., Waris, N., Shaheen, F., & Basit, A. (2021). Psychometric Analysis for fear of COVID-19 Scale (FCV-19S) and its association with depression in patients with diabetes: A cross sectional study from a Tertiary Care Centre in Karachi, Pakistan. *Diabetes & Metabolic Syndrome: Clinical Research & Reviews*, 15(3), 733-737. <http://doi.org/10.1016/j.dsx.2021.03.008>
- Bedford, J., Enria, D., Giesecke, J., Heymann, D. L., Ihekweazu, C., Kobinger, G., . . . Sall, A. (2020). WHO Strategic and Technical Advisory Group for Infectious Hazards. COVID-19: Towards controlling a pandemic. *Lancet*, 395(10229), 1015-1018. [http://doi.org/10.1016/S0140-6736\(20\)30673-5](http://doi.org/10.1016/S0140-6736(20)30673-5)
- Bednarczyk, R. A. (2018). Examining the "why" of vaccine hesitancy.
- Bitan, D. T., Grossman-Giron, A., Bloch, Y., Mayer, Y., Shiffman, N., & Mendlovic, S. (2020). Fear of COVID-19 scale: Psychometric characteristics, reliability, and validity in the Israeli population. *Psychiatry Research*, 289, 113100. <http://doi.org/10.1016/j.psychres.2020.113100>
- Brenner, M. H., & Bhugra, D. (2020). Acceleration of anxiety, depression, and suicide: secondary effects of economic disruption related to COVID-19. *Frontiers in psychiatry*, 11, 1422. <http://doi.org/10.3389/fpsy.2020.592467>
- Brislin, R. W. (1986). The wording and translation of research instruments.
- Byrne, B. M. (2013). *Structural equation modeling with EQS: Basic concepts, applications, and programming*: Routledge.
- Chandu, V. C., Pachava, S., Vadapalli, V., & Marella, Y. (2020). Development and initial validation of the COVID-19 anxiety scale. *Indian journal of public health*, 64(6), 201. http://doi.org/10.4103/ijph.IJPH_492_20
- Connor, K. M., & Davidson, J. R. (2003). Development of a new resilience scale: The Connor-Davidson resilience scale (CD-RISC). *Depression and anxiety*, 18(2), 76–82. <http://doi.org/10.1002/da.10113>
- Cook, D. A., & Beckman, T. J. (2006). Current concepts in validity and reliability for psychometric instruments: theory and application. *The American journal of*

- medicine*, 119(2), 166. e167-166. e116.
<http://doi.org/10.1016/j.amjmed.2005.10.036>
- De Rose, A. F., Chierigo, F., Ambrosini, F., Mantica, G., Borghesi, M., Suardi, N., & Terrone, C. (2021). Sexuality during COVID lockdown: a cross-sectional Italian study among hospital workers and their relatives. *International Journal of Impotence Research*, 33(1), 131-136. <http://doi.org/10.1038/s41443-020-00393-5>
- Döring, N. (2020). How is the COVID-19 pandemic affecting our sexualities? An overview of the current media narratives and research hypotheses. *Archives of sexual behavior*, 49(8), 2765–2778. <http://doi.org/10.1007/s10508-020-01790-z>
- Hajizadeh, E., & Asghari, M. (2011). Statistical methods and analyses in health and biosciences: a research methodological approach. *Tehran: Jahade Daneshgahi Publications*, 395.
- Hirschberger, G. (2013). Self-protective altruism. *Social and Personality Psychology Compass*, 7(2), 128-140. <https://doi.org/10.1111/spc3.12013>
- Karagöz, M. A., Gül, A., Borg, C., Erihan, İ. B., Uslu, M., Ezer, M., . . . Bağcıoğlu, M. (2020). Influence of COVID-19 pandemic on sexuality: a cross-sectional study among couples in Turkey. *International Journal of Impotence Research*, 1-9. <https://doi.org/10.1038/s41443-020-00378-4>
- Korukcu, O., Ozkaya, M., Faruk Boran, O., & Boran, M. (2021). The effect of the COVID-19 pandemic on community mental health: A psychometric and prevalence study in Turkey. *Health & Social Care in the Community*. <https://doi.org/10.1111/hsc.13270>
- Lawshe, C. H. (2006). A Quantitative Approach to Content Validity. *Personnel Psychology*, pp. 28, 563–575. <https://doi.org/10.1111/j.1744-6570.1975.tb01393.x>
- Lee, S. A., Mathis, A. A., Jobe, M. C., & Pappalardo, E. A. (2020). Clinically significant fear and anxiety of COVID-19: A psychometric examination of the Coronavirus Anxiety Scale. *Psychiatry Research*, p. 290, 113112. <https://doi.org/10.1016/j.psychres.2020.113112>
- Lopes, G. P., Vale, F. B. C., Vieira, I., da Silva Filho, A. L., Abuhid, C., & Geber, S. (2020). COVID-19 and sexuality: reinventing intimacy. *Archives of sexual behavior*, 49(8), 2735-2738. <https://doi.org/10.1007/s10508-020-01796-7>
- Magano, J., Vidal, D. G., Dinis, M. A. P., & Leite, Â. (2021). Validation and psychometric properties of the Portuguese version of the Coronavirus Anxiety Scale (CAS) and fear of COVID-19 Scale (FCV-19S) and associations with travel, tourism and hospitality. *International Journal of Environmental Research and Public Health*, 18(2), 427. <https://doi.org/10.3390/ijerph18020427>
- Memish, Z. A., Ahmed, Q. A., Schlagenhauf, P., Doumbia, S., & Khan, A. (2020). No time for dilemma: mass gatherings must be suspended. *The Lancet*, 395(10231), 1191-1192. [https://doi.org/10.1016/S0140-6736\(20\)30754-6](https://doi.org/10.1016/S0140-6736(20)30754-6)
- Mohammadi, M., Jazayeri, A. R., Rafie, A. H., Joukar, B., & Pourshahbaz, A. (2006). Resilience Factors in Individuals at Risk for Substance Abuse. *Journal of*

- Psychology (Tabriz University)*, 1(2-3), -. Retrieved from <https://www.sid.ir/en/journal/ViewPaper.aspx?ID=75843>
- Nikčević, A. V., & Spada, M. M. (2020). The COVID-19 anxiety syndrome scale: Development and psychometric properties. *Psychiatry Research*, 292, 113322. <https://doi.org/10.1016/j.psychres.2020.113322>
- Panzeri, M., Ferrucci, R., Cozza, A., & Fontanesi, L. (2020). Changes in Sexuality and Quality of Couple Relationship During the COVID-19 Lockdown. *Frontiers in Psychology*, 11(2523). <https://doi.org/10.3389/fpsyg.2020.565823>
- Petzold, M. B., Bendau, A., Plag, J., Pyrkosch, L., Maricic, L. M., Rogoll, J., . . . Ströhle, A. (2020). Development of the COVID-19-Anxiety Questionnaire and first psychometric testing. *BJPsych open*, 6(5). <https://doi.org/10.1192/bjo.2020.82>
- Plichta, S. B., Kelvin, E. A., & Munro, B. H. (2013). *Munro's statistical methods for health care research*: Wolters Kluwer Health/Lippincott Williams & Wilkins.
- Sakib, N., Bhuiyan, A. I., Hossain, S., Al Mamun, F., Hosen, I., Abdullah, A. H., . . . Hossain, M. (2020). Psychometric validation of the Bangla Fear of COVID-19 Scale: Confirmatory factor analysis and Rasch analysis. *International Journal of Mental Health and Addiction*, 1-12. <https://doi.org/10.1007/s11469-020-00289-x>
- Silva, W. A. D., de Sampaio Brito, T. R., & Pereira, C. R. (2020). COVID-19 anxiety scale (CAS): Development and psychometric properties. *Current Psychology*, 1-10. <https://doi.org/10.1007/s12144-020-01195-0>
- Silverstein, M., Mekawi, Y., Alonzi, S., & Torre, A. L. (2021). Psychometric properties of the assessment of COVID-19 attitudes and behaviors. *Analyses of Social Issues and Public Policy*. <https://doi.org/10.1111/asap.12233>
- Tabachnick, B. G., Fidell, L. S., & Ullman, J. B. (2007). *Using multivariate statistics* (Vol. 5): Pearson Boston, MA.
- WHO. COVID-19 Weekly Epidemiological Update; WHO: Geneva, Switzerland, 2022; Volume 7, 21p.
- Xie, Q., Fan, F., Fan, X.-P., Wang, X.-J., Chen, M.-J., Zhong, B.-L., & Chiu, H. F.-K. (2020). COVID-19 patients managed in psychiatric inpatient settings due to first-episode mental disorders in Wuhan, China: clinical characteristics, treatments, outcomes, and our experiences. *Translational Psychiatry*, 10(1), 1–11. <https://doi.org/10.1038/s41398-020-01022-x>
- Xie, X.-Q., He, W.-P., Gu, B., Mei, Y., & Wang, J. (2019). The robustness of the skewness as an early warning signal for abrupt climate change. *International Journal of Climatology*, 39(15), 5672-5687. <https://doi.org/10.1002/joc.6179>