

Investigating the Practical Applications of the Frequency Response of the Transformers Extracted Using the Lightning Impulse Test Results

H. R. Mirzaei

Department of Electrical Engineering, University of Zanjan, Zanjan, Iran

Abstract- The Lightning Impulse (LI) test is performed on newly manufactured power transformers as a routine Factory Acceptance Test (FAT). A well-known Marx Impulse Generator (MIG) is utilized in this test. The setting of the MIG can be changed to obtain standard LI wave shape. Since various power transformers may have windings with dissimilar designs, different MIG settings may be required for each transformer. The accurate computer simulation of the LI test circuit can give help in finding the optimum setting of the MIG. The Frequency Response (FR) of the power transformer impedance is required in such simulations. Similarly, the transformer FR is required in calculating the Transient Recovery Voltage (TRV) across the contacts of the Circuit Breakers (CB) in the case of the Transformer Limited Fault (TLF). The accurate calculation of such TRVs has a great importance in selecting the proper rating for CBs. The FR of the transformer can be measured directly with network analyzers or some other conventional test instruments. However, performing an additional test to obtain the transformer FR imposes extra cost and efforts. Alternatively, it can be achieved by using the routine LI test results which is readily available. Fortunately in both mentioned applications similar connections are required for transformer terminals. In this paper, the procedure to extract the transformer FR using the LI test results is presented. Then, the validity of such extracted FRs is investigated by comparing them with the ones measured by conventional test instruments. As an innovation, the extracted transformer FRs are used in the LI test circuit simulation and the accuracy of the method is examined by experimental works. Moreover, the application of the extracted FR in TLF TRV calculation is investigated as well. The validity of the all presented theoretical concepts are evaluated using the experimental test results on a real large power transformer.

Keyword: Transformer frequency response, Lightning impulse test, Transient recovery voltage, Circuit breaker, Transformer limited fault.

1. INTRODUCTION

The Lightning Impulse (LI) test is a routine dielectric Factory Acceptance Test (FAT) which is performed on newly manufactured power transformers. The Frequency Response (FR) of the transformer has a great influence on the wave shape of the impulse signal. The transformer FR is required in simulating its Lightning Impulse Test (LIT) circuit. Such a simulation is needed to find the optimum parameters of the Marx Impulse Generator (MIG) to achieve the standard LI wave shape [1-3]. Likewise, the FR of the transformer affects the Transient Recovery Voltage (TRV) across the contacts of a circuit breaker (CB) which opens a Transformer Limited Fault (TLF). Similarly, FR of the transformer is required in calculating parameters of such TRVs [4, 5].

Due to the distributed inductances, capacitances and resistances that exist in the High Frequency (HF) model of the transformer winding, its FR has a complex behavior in this frequency range [6, 7]. The transformer FR can be measured by conventional Frequency Response Analysis (FRA) test devices. Such devices usually implement either Sweep Frequency (SF) or Low Voltage Impulse (LVI) methods to excite the transformer and measure its response [8]. According to references [8] and [9] and regarding to the different choices for connecting the non-tested terminals of the transformer, various FRs can be measured in normal FRA tests. However, in both mentioned applications; the LI test circuit simulation and calculating the TRV, the FR of the transformer must be measured using a different special terminals connection. Therefore, performing an additional FRA test is compulsory. However, the FR of the transformer with this special connection can be measured readily by using the results of the routine LI test. This method for measuring the transformer FR is known as High Voltage Impulse (HVI) method [4, 10-13].

Received: Jan. 23, 2021

Revised: Jul. 7, 2021

Accepted: Aug. 16, 2021

*Corresponding author:

E-mail: hr.mirzaei@znu.ac.ir (Hassan Reza Mirzaei)

DOI: 10.22098/joape.2022.8341.1576

Applied paper

© 2022 University of Mohaghegh Ardabili. All rights reserved.

The exact modeling of the transformer's HF impedance is the bottleneck of the LI test circuit simulation. In Refs. [14] and [15] a simple parallel RLC circuit is used as a rough model of the transformer, which is not accurate enough. Therefore, in Refs. [3, 16] the direct measurement of the transformer's FR by FRA measurement is used to construct a complex RLC model for transformer winding. To avoid this complex model, in Refs. [1] and [2], the author has used the FRA measurement to find the FR of the transformer's impedance and solved the test circuit by Discrete Fourier Transform (DFT) and Laplace transform respectively. The reasonable match of the simulation and measured LI waveforms in Refs. [1] and [2] approves the accuracy of delivered solutions. However, this method still requires performing an extra time consuming FRA measurement.

In the LI test, the setting of the MIG shall be carefully chosen to attain the standard LI wave shape in accordance with IEC 60076-3 [17]. Since transformers with dissimilar designed windings have different FRs, different MIG settings are required in the LI test to obtain standard wave shape. The appropriate setting of the MIG in the LI test of each transformer is usually determined in a manual time consuming try and error procedure. In this procedure, several successive LITs are performed on the transformer. After each test, some changes are made to the MIG setting according to the expertise of the test engineers to obtain the standard wave shape in the next tests. In this paper, a novel method is introduced to extract the FR of the transformer at the first LI test. In such a way, the need for performing additional FRA test can be resolved. The extracted FR can be used to accurately simulate the LI test circuit simulation by computers. Such simulations can be adopted in the optimization programs to find the optimum MIG setting [2, 3]. Using this setting, the standard wave shape can be attained in the second LI test, and neither further LI test nor extra FRA test are required.

To compute the TRV of a CB in a TLF, some empirical curves are provided in Refs. [18] and [19] to extract the transformer's simple RLC model. The most important drawback of this method is the lack of certainty in estimating the exact values of the model parameters. Some research works about TRV calculation like Refs. [5, 20-21] utilized FRA test results to extract the parameters of the RLC model of the transformer. In Ref. [22], different methods for TRV calculations are compared and investigated; in all the mentioned methods the FR of the transformer is needed. However

in Ref. [23], the FRA results were used directly to obtain the TRV by using DFT. In all of these research works, an additional FRA test is required. However, the FR of the transformer can be accessed through the available routine LI test results.

In this paper, the principles of the mentioned issues are discussed, and then, their validities are investigated by the experiments performed on a real large power transformer. The structure of the paper is as follows; the basic concepts and the simulation methods of both the LI test as well as the TLF TRV are presented in sections II and III respectively. Afterwards, the SF and HVI methods to measure the required FR of the transformer impedance are discussed in section IV. In section V, the accuracy of the HVI method in determining the transformer FR is investigated by using some experimental test results. The validity of the proposed LIT and TRV simulation methods are studied as well. Finally, the conclusion of the paper is included in section VI.

2. THE PRINCIPLES OF THE LIT CIRCUIT SIMULATION

The main part of the LIT circuit is a multistage Marx impulse generator. As is shown in Fig. 1, each stage of the MIG consists of a trigger spark gap, a stage impulse capacitor C_S and series and parallel resistors denoted by R_S and R_P respectively. A rectifier charges the stage capacitors through some charging resistors up to a desired DC voltage, V_0 . Then, by triggering the spark gaps, the stage capacitors will be discharged, at first, through the series resistors to the capacitance of the transformer which will make the front time, and then through the parallel resistors which will form the fall time of the LI wave shape [1, 24]. The stages of the MIG could be connected in parallel and series to form a generator construction. The construction of the generator is identified by the parameters N_P and N_S ; which indicates N_P stages are connected in parallel to create a single unit, and then N_S similar units are connected in series [1].

In the transformer LI test, the terminal under test must be connected to the MIG, divider and chopper, while all other terminals shall be connected to the grounded tank directly (Fig. 2). The impulse current through the lead connecting the transformer tank to the earth pot can be measured using a low impedance measuring shunt as an indication of the test success or failure [17]. In Ref. [1], the author has provided a simple accurate solution for simulating the LI test circuit and obtained a

straightforward equation to calculate the LI output signal in Laplace domain:

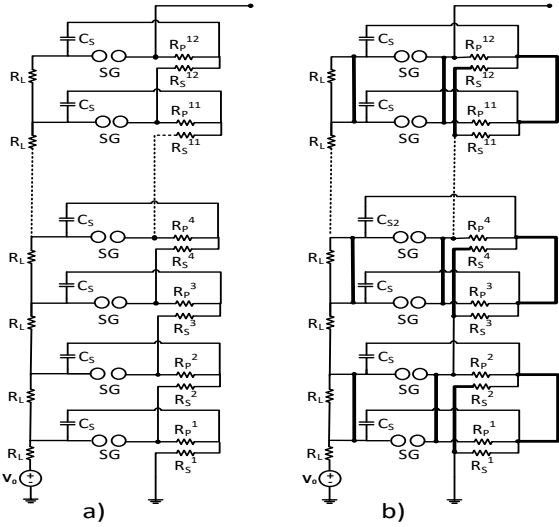

Fig. 1. The diagram of a 12 stage Marx impulse generator, V_0 : the DC charging voltage, C_s : stage capacitor, R_s^k and R_p^k : series and parallel resistors of the k th stage respectively, SG: spark gap, R_L : loading resistor, a) $N_p=1, N_s=12$ and b) $N_p=2, N_s=6$

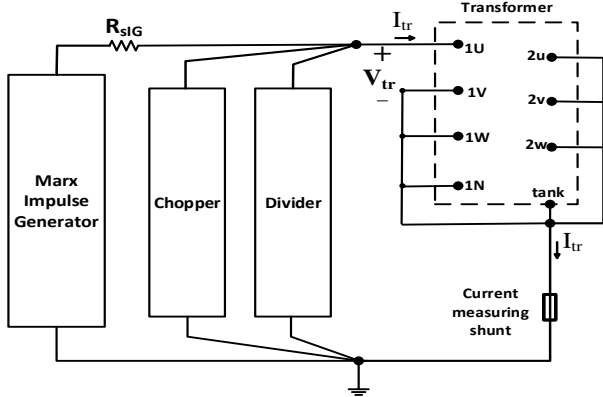

Fig. 2. The schematic diagram of a transformer's LIT circuit connections

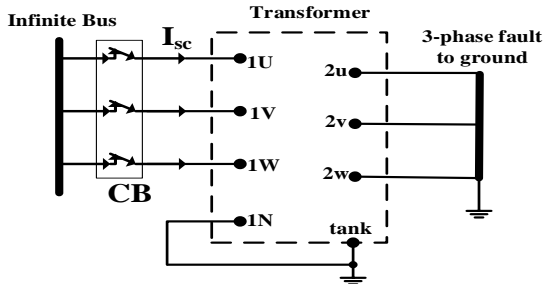

Fig. 3. A three-phase to ground TLF

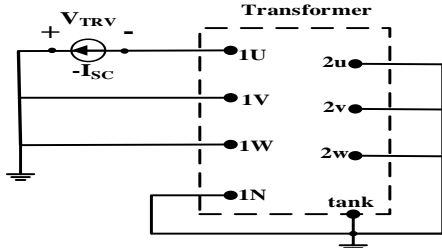

Fig.4. The current injection method to calculate the TRV of the FPTC, shown in Fig. 3

$$V_{tr}(s) = \frac{Z_{21} \frac{1 - e^{-sN_s t_d}}{1 - e^{-s t_d}} \cdot \frac{V_0}{s}}{Z_{11}(1 + YZ_{sIG}) + N_s \Delta Z^2 (Y_{CpIG} + Y(1 + Y_{CpIG} Z_{sIG}))} \quad (1)$$

where V_{tr} is the impulse voltage, s is the Laplace variable and t_d is the trigger time delay between the surge gaps of the MIG. By assuming identical values for the series and parallel resistors at all MIG stages and ignoring the inter-stage parasitic capacitance (just for simplicity and without reducing the required accuracy of the simulation), we have:

$$Z_{11} = \frac{(R_p + sL_{Rp}) + (\frac{1}{sC_s} + sL_{Cs})}{N_p}$$

$$Z_{12} = Z_{21} = \frac{(R_p + sL_{Rp})}{N_p}$$

$$Z_{22} = \frac{(R_s + sL_{Rs}) + (R_p + sL_{Rp})}{N_p}$$

$$\Delta Z^2 = Z_{11}Z_{22} - Z_{12}Z_{21} \quad (2)$$

$$Y = \frac{1}{Z_{tr}} + \frac{1}{Z_{Div} + Z_{sDiv}} + \frac{1}{Z_{Chop} + Z_{sChop}}$$

$$Z_{sDiv} = sL_{sDiv}$$

$$Z_{sChop} = sL_{sChop}$$

$$Z_{sIG} = R_{sIG} + sL_{sIG}$$

$$Y_{CpIG} = sC_{pIG}$$

where L_{Rs} and L_{Rp} are the parasite inductances of series and parallel stage resistors, L_{Cs} is the parasite inductance of the stage capacitor, Z_{tr} is the measured FR of the transformer impedance, Z_{Div} and Z_{Chop} are the impedances of the divider and the chopper respectively, Z_{sDiv} , Z_{sChop} and Z_{sIG} are the series impedances of the HV lead connected to the divider, the chopper and the MIG respectively, L_{sDiv} , L_{sChop} and L_{sIG} are the parasite inductances of the mentioned HV leads, R_{sIG} is the external resistor in series with the MIG, and C_{pIG} is the parallel parasite capacitance between the MIG's top head and the ground [1].

3. THE PRICIPLES OF THE TRV CALCULATION OF TLF

The CBs are essential parts in power grids to isolate them from short circuit faults. During the opening operation of a CB, a TRV appears across its contacts. The high amplitude of the TRV as well as its rate of rise may result into arc re-ignition and so to a catastrophic failure of the CB. Although in a TLF, the short circuit current is limited by transformer impedance to 10% upto 30% of the rated breaking current of the CB, associated Rate of Rise of Recovery Voltage (RRRV) and its peak value is very high [18]. The TRV wave shapes of the

TLFs are mainly determined by the HF impedances of the transformers; the maximum relevant bandwidth is some 100 kHz with dominant frequencies around ten to some tens of kHz [25].

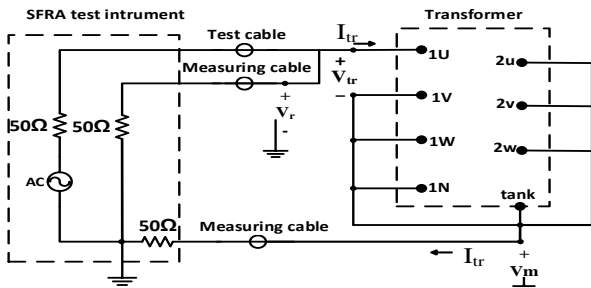

Fig. 5. The FRA measuring device and the connections of the transformer terminals to measure its impedance FR



Fig. 6. The routine LI FAT setup on the 230/63/20 kV, 160 MVA power transformer at the HV test Lab

Fig. 3 shows a three phase short circuit TLF to ground. It can be considered that a symmetric three phase earth fault for TRV calculations covers the great majority of the power system faults. After parting the CB contacts, arcs are ignited in all of its three poles. Bearing in mind the time delays between the three phases sinusoidal current zeros, the pole which reaches first to its current zero passing instant will extinguish its arc. The TRV wave shape of the First Pole to Clear (FPTC), has the most severe characteristics at the TLF [18, 26]. According to the current injection method to calculate the TRV [27], one can set the values of all sources of power system to zero, and replace the FPTC of the CB by a current source with the same magnitude of the fault current but with a reversed direction (Fig. 4). Hence, in the resultant equivalent circuit, the second and third poles of the CB are directly connected to the ground. The voltage across the current source in Fig. 4 will be equal to the TRV. Since the TRV oscillations just take some hundreds of microseconds to be fully damped out, this sinusoidal power frequency current source can be replaced by a ramp current source with the

same slope of the power frequency fault current at its zero [27]:

$$i(t) = 2\sqrt{2}\pi f_0 I_{sc} t \quad (3)$$

where I_{sc} is the effective value of the fault current and f_0 is the power frequency, whether 50 or 60 Hz. Using the Laplace transform, the TRV will be calculated as:

$$V_{TRV}(s) = Z_{tr}(s) \cdot I(s) = Z_{tr}(s) \cdot \frac{2\sqrt{2}\pi f_0 I_{sc}}{s^2} \quad (4)$$

where $Z_{tr}(s)$ is transformer's impedance in Laplace domain. By comparing the transformer terminals connections in Fig. 2 and Fig. 4, one can notice that they are identical. Therefore, it can be concluded that the FR of the transformer impedance, $Z_{tr}(s)$, in both applications are the same. By converting Eq. (4) to DFT domain, one obtains:

$$V_{TRV}(j\omega) = Z_{tr}(j\omega) \cdot \frac{2\sqrt{2}\pi f_0 I_{sc}}{(j\omega)^2} \quad (5)$$

where $\omega = 2\pi f$ is the discrete angular frequency vector, and f is the discrete frequency vector. Now the TRV wave shape in the time domain can be calculated simply by Inverse Fast Fourier Transform (IFFT):

$$v_{TRV}(t) = \text{iffT}(V_{TRV}(j\omega)) \quad (6)$$

4. CALCULATING THE FR OF THE TRANSFORMER IMPEDANCE

4.1. Calculating the Transformer FR by LI test results (HVI method)

To calculate the FR of the transformer impedance, a primitive LI test with reduced amplitude, e.g. 50% of the test voltage, must be performed at first. Then, the related impulse voltage and current signals must be acquired via HV divider and current shunt respectively. To increase the accuracy of the method, it is reasonable to adjust the MIG setting at this primitive test according to the expertise of the test engineers to attain a LI wave shape as close as possible to standard 1.2/50 μ s wave shape.

Considering the LI test circuit of Fig. 2, the recorded signals of the LI voltage and current in time domain, $v_{tr}(t)$ and $i_{tr}(t)$ respectively, can be used to calculate the FR of the transformer; their Fast Fourier Transform (FFT) must be extracted, and consequently, one can obtain the FR of the transformer impedance as follows:

$$Z_{tr}(j\omega) = \frac{\text{fft}(v_{tr}(t))}{\text{fft}(i_{tr}(t))} \quad (7)$$

To enhance the accuracy of the measured FR at low frequencies, it is mandatory to record both voltage and current signals until their energies completely fall to zero; e.g. until 2 ms. Considering t_s as the sampling time and t_{end} as the recording time span, the upper limit frequency of the FFT, f_{end} , and the frequency resolution,

Δf , can be determined as follows:

$$f_{end} = \frac{t_s}{2} \tag{8}$$

$$\Delta f = \frac{1}{t_{end}} \tag{9}$$

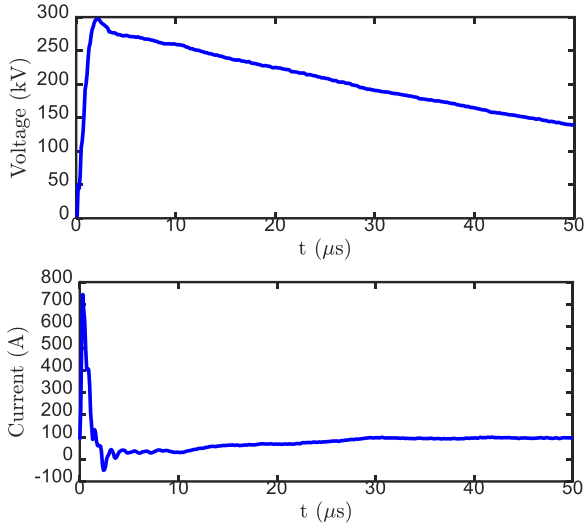

Fig. 7. The measured LI voltage (upper) and current (lower) signals at the HV side of the transformer

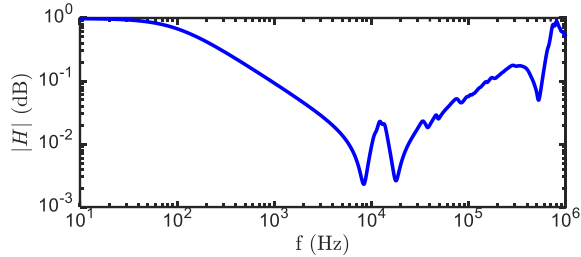

Fig. 8. The measured $H(j\omega)$ response by FRA test at the HV side of the transformer

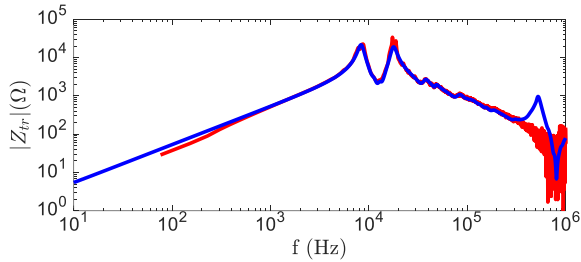

Fig. 9. Comparing the $Z_{tr}(j\omega)$ at the HV side of the transformer, calculated by the LIT result (red) and FRA test result (blue)

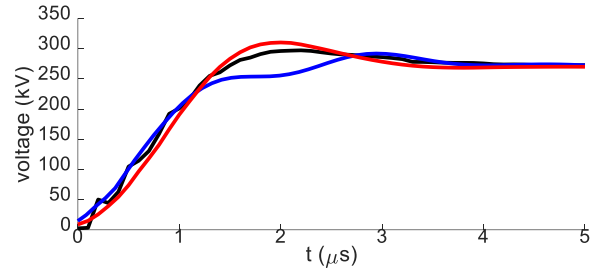
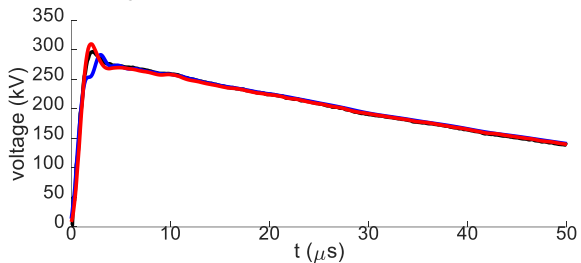

Fig. 10. Comparing the measured LI wave shape (black) with the simulated ones using $Z_{tr}(j\omega)$ obtained from LIT (red) and FRA test (blue) at the HV side of the transformer, upper: full view, lower: zoomed view

4.2. Calculating the Transformer FR by FRA test results

The validity of the method to extract the FR of the transformer by the LIT can be investigated by comparing its result with the one measured directly by a conventional FRA test device. As shown in Fig. 5, the connections of the transformer terminals at FRA test must be identical with their connections in the LIT. In the FRA test, a variable frequency sinusoidal voltage (SF method) is applied as an input to the tested terminal and is recorded simultaneously as V_r . Meanwhile, the output signal, V_m , is measured and recorded from the tank of the transformer. It must be noticed that some 50 Ω resistors are used in the FRA test device to eliminate the reflections. The output of FRA measurement is [1-3]:

$$H(j\omega) = \frac{V_m(j\omega)}{V_r(j\omega)} \tag{10}$$

According to Fig. 5, the transformer HF impedance can be calculated as:

$$Z_{tr}(j\omega) = \frac{V_{tr}(j\omega)}{I_{tr}(j\omega)} = \frac{V_m(j\omega) - V_r(j\omega)}{V_m(j\omega)/50} = \frac{50(1 - H(j\omega))}{H(j\omega)} \tag{11}$$

5. EXPERIMENTAL VALIDATION

To investigate the accuracies of the methods, some experiments were performed on the HV, LV and TV sides of a 230/63/20 kV, 160 MVA, YNyn0d11 power transformer. In these experiments, the $Z_{tr}(j\omega)$ of each side of the transformer was calculated by two methods; by means of the LI and the FRA tests, and then they were compared as the first verification method. It must be noted that all performed LITs were executed in reduced voltages. The second verification procedure was to simulate the LI test circuit by using both obtained transformer FRs and compare the simulated wave shapes with the measured one. Finally, the TLF TRV of each side of the transformer was computed by using their FRs that obtained by two mentioned methods, and the simulated curves are compared as the last verification method. It must be noted that the values of the short circuit currents in TRV calculations were obtained by dividing the nominal current of the transformer to its

percent impedance.

In the LI FAT, a 12 stage, 2400 kV, 240 kJ conventional MIG with $C_s=1 \mu\text{F}$ was used (Fig. 6). The stage capacitors and damping resistors of the 3-stage divider and chopper are $C_{div}=1873 \text{ pF}$, $R_{div}=66 \Omega$, $C_{chop}=1500 \text{ pF}$ and $R_{chop}=66 \Omega$ respectively. The voltage and current signals were measured and recorded by a conventional 10 bit, 10 MS/s digitizer. However, it must be mentioned that the noise level will be high by this low sampling rate, and therefore, it is recommended in Ref. [11] to implement the sampling rate of 50 MS/s.

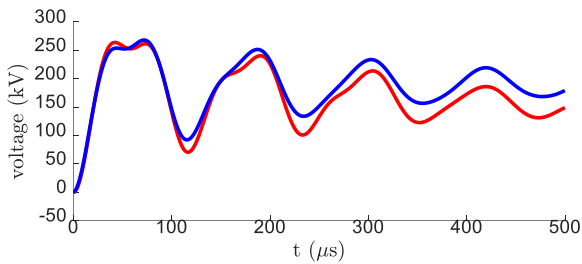

Fig. 11. Comparing the simulated TRV at the HV side of the transformer using $Z_r(j\omega)$ obtained by LIT result (red), FRA test result (blue)

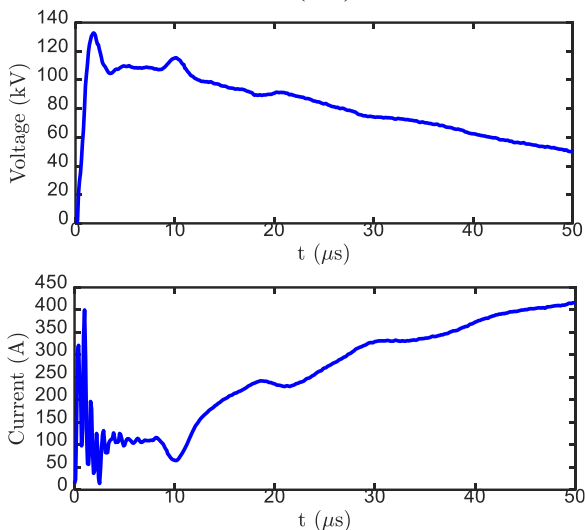

Fig. 12. The measured LI voltage (upper) and current (lower) signals at the LV side of the transformer

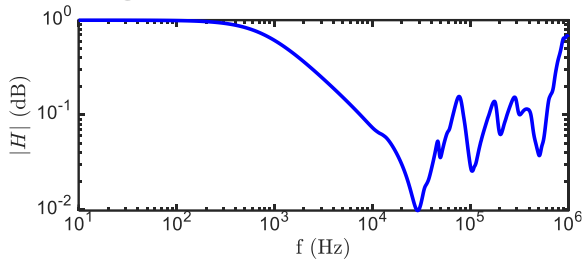

Fig. 13. The measured $H(j\omega)$ response by FRA test at the LV side of the transformer

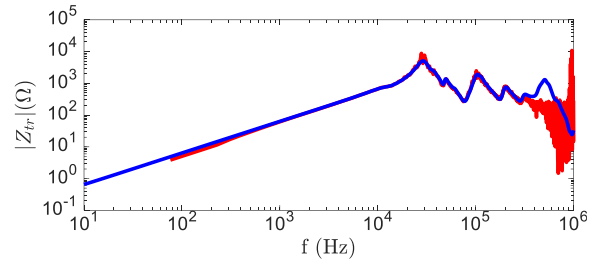
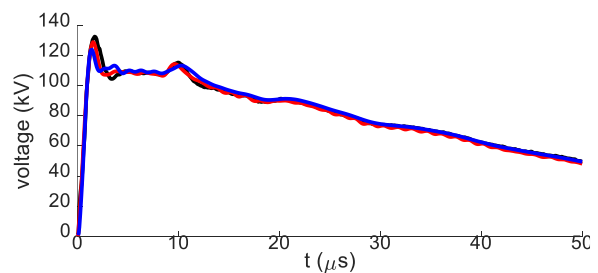

Fig. 14. Comparing the $Z_r(j\omega)$ at the LV side of the transformer, calculated by the LIT result (red) and FRA test result (blue)

5.1. The results at the HV side of the transformer

At the LIT of the HV side of the transformer, the MIG setting was selected as $N_s=12$, $N_p=1$, $R_s=16 \Omega$ and $R_p=130 \Omega$; the measured LI voltage and current signals are shown in Fig. 7. Likewise, the $H(j\omega)$ response measured by a conventional FRA test device at the HV side is displayed in Fig. 8. The calculated $Z_r(j\omega)$ of the transformer using the LIT result and (7) is compared with the one calculated by the FRA test result and (11) in Fig. 9. As is shown in this figure, both curves are in suitable match with each other. However, some oscillations can be observed for $Z_r(j\omega)$ obtained by LIT result at frequencies higher than 400 kHz, which is due to the low energy content of the impulse signals at this frequency range, the low sampling rate of the digitizer (about 10 MS/s) and its limited vertical resolution of 10 bit. By enhancing the digitizer's resolution and sampling rate, it is possible to increase the signal to noise ratio of the digital signals and increase the valid upper frequency limit. Yet, it must be noted here that according to [28], the frequency content of the standard 1.2/50 μs LI wave shape is below 400 kHz, and also a same fact is confirmed about the TRV in Ref. [25]. Therefore, such mismatch between two obtained FRs will not affect the accuracy of the LIT and TRV simulations. Using both obtained $Z_r(j\omega)$, the LIT circuit of the transformer was simulated considering the MIG setting and (1), and the results are compared with the measured one in Fig. 10. It is clear to see that both simulation results are in reasonable accordance with the measured LI voltage, though, the simulation with $Z_r(j\omega)$ that is obtained from LIT follows the measured signal better than the other one at front of the wave.



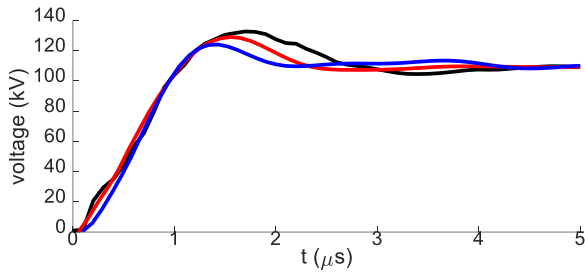

Fig. 15. Comparing the measured LI wave shape (black) with the simulated ones using $Z_{tr}(j\omega)$ obtained from LIT (red) and FRA test (blue) at the LV side of the transformer, upper: full view, lower: zoomed view

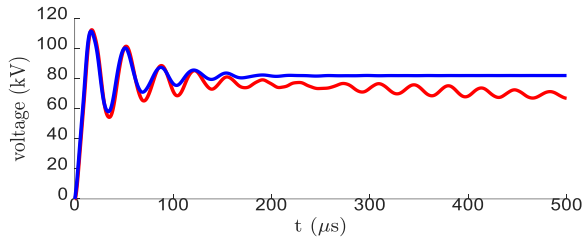

Fig. 16. Comparing the simulated TRV at the LV side of the transformer, using $Z_{tr}(j\omega)$ obtained by LIT result (red), FRA test result (blue)

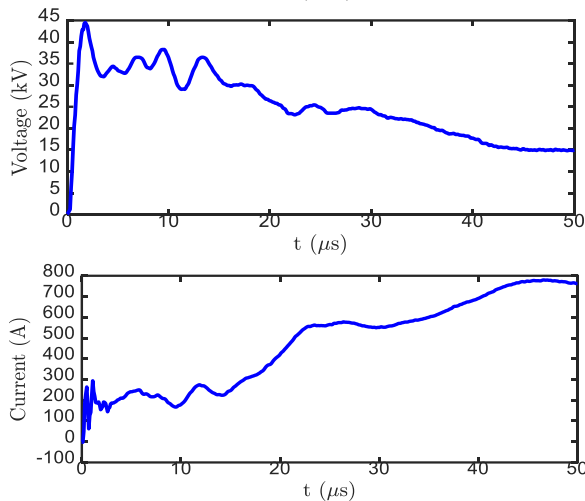

Fig. 17. The measured LI voltage (upper) and current (lower) signals at the TV side of the transformer

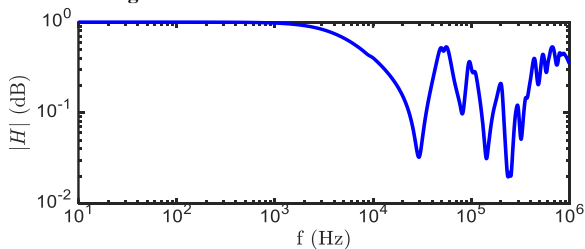

Fig. 18. The measured $H(j\omega)$ response by FRA test at the TV side of the transformer

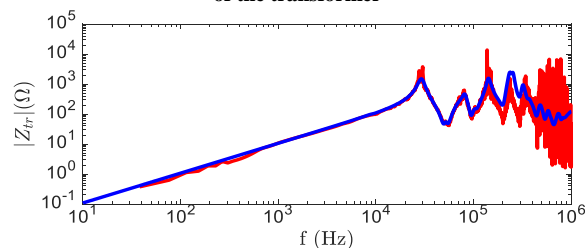

Fig. 19. Comparing the $Z_{tr}(j\omega)$ at the TV side of the transformer, calculated by the LIT result (red) and FRA test result (blue)

Likewise, the TLF TRV curves were calculated by the $Z_{tr}(j\omega)$ obtained by both methods and are compared in Fig. 11. It is clear to see that both curves have similar RRRVs, peak values and oscillation frequencies.

5.2. The results at the LV side of the transformer

The measured LI voltage and current signals in the LIT as well as the $H(j\omega)$ response measured by the FRA test at the LV side of the transformer are shown in Fig. 12 and 13 respectively. The implemented MIG setting was $N_S=4$, $N_P=2$, $R_S=55.5 \Omega$ and $R_P=6500 \Omega$. As is shown in Fig. 14, and similar to the HV side, the extracted $Z_{tr}(j\omega)$ by both method are analogous up to 400 kHz. Moreover, Fig. 15 demonstrates a good agreement between the measured LI voltage and the two curves obtained by simulating the LIT circuit by both achieved transformer impedances. Furthermore, as is demonstrated in Fig. 16, the two simulated TLF TRVs have similar RRRVs, peak values and oscillation frequencies.

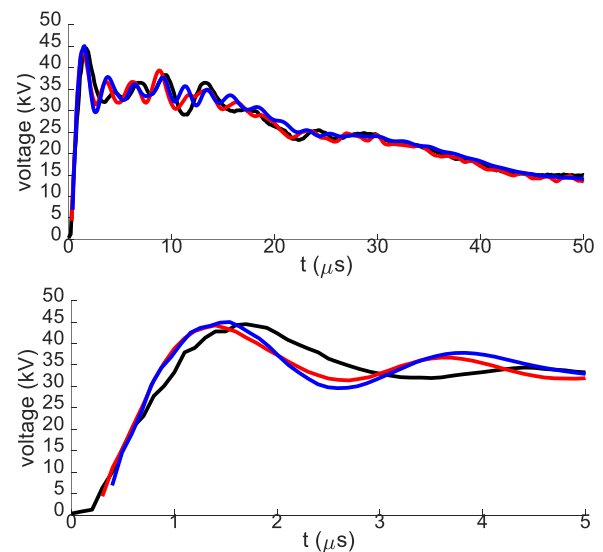

Fig. 20. Comparing the measured LI wave shape (black) with the simulated ones using $Z_{tr}(j\omega)$ obtained from LIT (red) and FRA test (blue) at the TV side of the transformer, upper: full view, lower: zoomed view

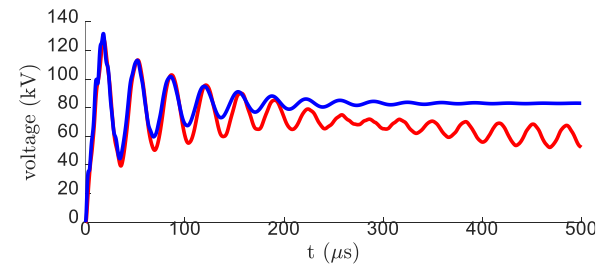

Fig. 21. Comparing the simulated TLF TRV at the TV side of the transformer, using $Z_{tr}(j\omega)$ obtained by LIT result (red), FRA test result (blue)

5.3. The results at the TV side of the transformer

The MIG setting at the LIT of the TV side of the transformer was applied as $N_s=1$, $N_p=3$, $R_s=65 \Omega$ and $R_p=900 \Omega$, and the resultant voltage and current signals are shown in Fig. 17. The FRA test result is displayed in Fig. 18. Similar verifications that were used for HV and LV sides, were applied to the measurement results at TV side, and the outcomes are shown in Fig. 19 to Fig. 21. Both mentioned methods for extracting the $Z_{tr}(j\omega)$ of the transformer result into similar outcomes in both LI and TRV simulations.

6. CONCLUSIONS

The HF response of transformer's impedance with special terminal connections is needed for simulating the LIT circuit and to find the TLF TRV as well. As an alternative to perform an additional FRA test to obtain this impedance, the test results of the routine LI FAT can be used. In this paper, the theoretical background of this method was discussed, and the methods for LIT circuit simulation and the TLF TRV calculation were provided as well. To investigate the accuracy of these methods, some experimental tests were performed on the HV, LV and TV sides of a power transformer. It was shown that the frequency responses of the transformer impedances which were obtained by LIT results are in good match with the ones obtained from FRA tests. Also, it was observed that by using the transformer FR which was extracted by LIT results, the LIT circuits can be simulated accurately. Therefore, the need for additional FRA test as well the need for numerous try and error LI tests to find the optimum setting of the MIG can be avoided. Likewise, it was found that TLF TRV calculations using the transformer impedances obtained by both LIT and FRA tests, result into similar waveforms.

Acknowledgement

The author gratefully acknowledges the cooperation of test engineers of the Iran-Transfo company HV test field for their cooperation in experimental tests.

REFERENCES

- [1] H. R. Mirzaei, "A simple fast and accurate simulation method for power transformer lightning impulse test", *IEEE Trans. Power Del.*, vol. 34, pp. 1151-60, 2019.
- [2] H. R. Mirzaei, F. Bayat, K. Miralikhani, "A semi-analytic approach for determining marx generator optimum setup during power transformers factory test", *IEEE Trans. Power Del.*, vol. 36, pp. 10-18, 2021.
- [3] K. Samarawickrama et al., "Impulse generator optimum setup for transient testing of transformers using frequency-response analysis and genetic algorithm", *IEEE Trans. Power Del.*, vol. 30, pp. 1949-57, 2015.
- [4] W. Hribernik, L. Graber, J. Brunke, "Inherent transient recovery voltage of power transformers – a model-based determination procedure", *IEEE Trans. Power Del.*, vol. 21, pp. 129-34, 2006.
- [5] H. Ito et al., "Study on transient recovery voltages for transformer-limited faults", *IEEE Trans. Power Del.*, vol. 29, pp. 2375-84, 2014.
- [6] E. Rahimpour et al., "Transfer function method to diagnose axial displacement and radial deformation of transformer windings", *IEEE Trans. Power Del.*, vol. 18, pp. 493-505, 2003.
- [7] A. Akbari et al., "Transfer function-based partial discharge localization in power transformers: A feasibility study", *IEEE Elec. Ins. Mag.*, vol. 18, pp. 33-42, 2002.
- [8] IEEE Guide for the Application and Interpretation of Frequency Response Analysis for Oil-Immersed Transformers, C57.149-2012.
- [9] IEC60076-18, Measurement of frequency response, 2012.
- [10] R. Malewski, B. Poulin, "Digital monitoring technique for HV impulse tests", *IEEE Trans. Power App. Syst.*, vol. 104, pp. 3108-16, 1985.
- [11] M. Wang, A. Vandermaar, K. Srivastava, "Condition monitoring of transformers in service by the low voltage impulse test method", *11-th Int. Symp. High Vol. Eng.*, London, England, 1999.
- [12] T. Leibfried, K. Feser, "Monitoring of power transformers using the transfer function method", *IEEE Trans. Power Del.*, vol.14, pp. 1333-41, 1999.
- [13] E. Hanique, "A transfer function is a reliable tool for comparison of full and chopped lightning impulse tests", *IEEE Trans. Power Del.*, vol.9, pp. 1261-66, 1994.
- [14] S. Okabe et al., "Development of high frequency circuit model for oil-immersed power transformers and its application for lightning surge analysis", *IEEE Trans. Diel. Elec. Ins.*, vol. 18, pp. 541-52, 2011.
- [15] R. Vecchio et al., "Determining ideal impulse generator settings from a generator-transformer circuit model", *IEEE Trans. Power Del.*, vol. 17, pp. 42-8, 2002.
- [16] B. Gustavsen, "Wide band modeling of power transformers", *IEEE Trans. Power Del.*, vol. 19, pp. 414-22, 2004.
- [17] IEC60076-3, Power Transformers-Part 3: Insulation levels, dielectric tests and external clearances in air, 2000.
- [18] R. Harner, J. Rodriguez, "Transient recovery voltages associated with power-system, three-phase transformer secondary faults", *IEEE Trans. Power App. Syst.*, vol. 91, pp. 1887-96, 1972.
- [19] R. Harner, "Distribution system recovery voltage characteristics: I-transformer secondary-fault recovery voltage investigation", *IEEE Trans. Power App. Syst.*, vol. 87, pp. 463-87, 1968.
- [20] T. Myomin et al., "Investigation of EMTP transformer model for TRV calculation after fault current interrupting by using FRA measurement", *IEEE Power Energy Soc. T&D*, New Orleans, LA, USA, 2010.
- [21] T. Koshizuka et al., "TRV under transformer limited fault condition and frequency-dependent transformer model", *IEEE Power Energy Soc. Gen. Meet.*, San Diego, CA, 2011.
- [22] A. Teymouri et al., "A comparative review of different transformer modelling methods in TRV studies in case of transformer limited faults", *Eng. Sci. Tech. Int. J.*, vol. 22, pp. 600-9, 2019.
- [23] M. Steurer, W. Hribernik, J. Brunke, "Calculating the transient recovery voltage associated with clearing

- transformer determined faults by means of frequency response analysis”, *IEEE Trans. Power Del.*, vol. 19, pp. 168-73, 2004.
- [24] K. John, P. Kuffel, High voltage engineering fundamentals, 2000.
- [25] R. Smeets et al., “Switching in electrical transmission and distribution systems”, Wiley, 2015.
- [26] P. Parrott, “A review of transformer TRV conditions”, CIGRE WG 13.05, *ELECTRA*, no. 102, pp 87-118.
- [27] R. Garzon, High voltage circuit breakers, design and applications, 2nd ed., Marcel Dekker Inc., 2002, chapter 3, Basel, New York.
- [28] K. Schon, High Impulse Voltage and Current Measurement Techniques, Fundamentals Measuring Instruments Measuring Methods, 1st ed., 2013, chapter 3, Springer, Switzerland.